

KIRPY

The stone clearance specialist



STONE AND PLANT CRUSHERS



BPS

BPS 150

BPS 200

BPS 250

BPS 300



www.kirpy.com

BPS 150 - 200 - 250 - 300

RESEARCH AND INNOVATION, A PASSION...

KIRPY is continually researching, innovating and testing its equipment and developing it technically for better reliability.

KIRPY, which is always ready to listen to professionals in public works, forestry, agricultural or the mountains, has designed a new generation of fixed hammer stone crushers which are even more powerful and more profitable for your business.

BPS 300 complies with the increase of power tractors for a maximum of performance.



DIAGRAM BPS

- 1 Rotor
- 2 Transmission
- 3 Linkage
- 4 Controlled breaker
- 5 Hammers
- 6 Hydraulic expansion flap
- 7 Centralised automatic lubrication system

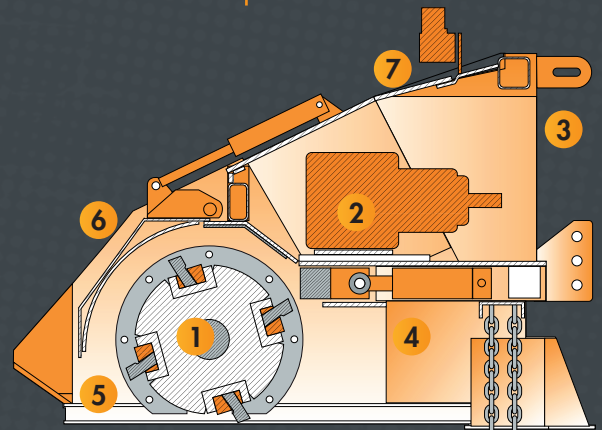

MOUNTAIN CRUSHING WORK:
MARKING OUT AND PREPARATION OF SKI PISTES

CRUSHING WITH CLOSE ANVIL :
CRUSHING CAPACITY : 0/20 – 0/40



FORESTRY WORK:
CREATION AND REPAIRS TO FOREST PATHS OR FIRE BREAKS.



PIPE-LINE LAYING : CRUSHING OF EXCAVATION PRODUCTS FOR LAYING BEDS AND COVERING (PATENTED).

RECYCLING MATERIAL : CRUSHING OF GRANITE,
CRUSHING OF BEDROCK FOR: PLATFORM, CYCLE TRACK, ...

CRUSHING WITH OPEN ANVIL :
CRUSHING CAPACITY : 0/40 – 0/60.



BPS: POWER, QUALITY AND ADAPTABILITY.

In order to guarantee the quality of its equipment, each stage in production is subject to continual quality controls to optimise reliability and performance. Today, the “yellow crushers” are the reference for contractors for their reliability and strength.

- VERY HIGH TENSILE STEEL WELDED ROTOR
- ROTOR PROTECTION PLATES INTERCHANGEABLE (BPS 250 – BPS 300)
- NEW PANELS BPS 250/300.
- EASY ACCESSIBILITY IN ALL ORGANS OF TRANSMISSION.
- AUTOMATIC TENSIONING BELTS.



BPS: TECHNOLOGY AND PERFORMANCE.

Speed and effectiveness of work:
this is the KIRPY BPS concept
which takes the form of:

- A large diameter rotor.
- A carefully planned distribution of the hammers for even work.
- A hydraulically controlled breaker anvil.
- Automatic belt tensioning.



THE STRONG POINTS OF KIRPY BPS ARE:

- Low cost hardened steel fixed hammers.
- A strengthened large diameter rotor providing depth and high output.
- A hydraulically controlled breaker plate for particle size selection.
- A double drive and automatic belt tensioning.
- A hydraulically controlled expansion flap.
- Interchangeable soles for deep working.
- Steel and components of very high quality.
- Low operating costs.
- Centralised automatic lubrication system in series (BPS 250/3).
- Interior casing completely interchangeable.
- Working depth : 20/25 cm.

HAMMERS CARBIDE STANDARDS HAMMERS CARBIDES PUBLIC WORKS



TECHNICAL SPECIFICATIONS	BPS 150	BPS 200	BPS 250/3	BPS 300
WORKING WIDTH (M)	1,50	2,00	2,50	3,00
WORKING DEPTH (CM)	20/25	20/25	20/25	20/25
WEIGHT (KG)	2250	3060	4200	5250
NEEDED POWER (HP)	130	150	200/250	250/300
NUMBER OF HAMMERS	16	24	32	40
P.T.O SPEED (r.p.m)	1000	1000	1000	1000
BELTS	SPC 2240 X 6	SPC 2240 X 8	XPC 2240 X 10	XPC 2240 X 10
CENTRALISED AUTOMATIC LUBRICATION SYSTEM	OPTION	OPTION	SÉRIE	SÉRIE

KIRPY

Avenue de la Gare
BP 2 - 47390 LAYRAC
Tél : +33 (0)5 53 87 00 02
Fax +33 (0)5 53 87 10 02
info@kirpy.com
www.kirpy.com



Dealer :