

# APF 1033

## FORWARD MOVING VIBRATORY PLATE



### AN EASY-TO-OPERATE OPTION

The APF 1033 is the lightest and smallest of all Ammann Vibratory Plate Compactors. Its size makes it ideally suited to small jobsites and confined areas. This forward-moving plate compactor is often utilised by landscape contractors to reach hard-to-access spots. Homeowners also use the APF 1033 because of its manageable size. The standard guide handle and its vibration isolation improve operator comfort. When the job is finished, the compactor is small enough to fit in the trunk of a car.

### EFFECTIVE COMPACTION TOOL

- Powerful petrol engine.
- Engine power transmitted to the exciter system through a centrifugal clutch and V belt.
- Optional water sprinkler system for work on bituminous surfaces.

### LIMITED MAINTENANCE

- Well-protected, robust centrifugal clutch with wear-resistant V belt.
- Service-friendly exciter unit with long lifetime.
- Wear-resistant, self-cleaning base plate.

### READY TO RENT

- Low-cost upkeep.
- Good match for many applications.
- Easy for new users to operate.

### INNOVATIVE HANDLE

- Vibration-isolated to reduce stress on the operator
- Foldable and removable, crucial attributes when working in confined areas or during transport.

### APPLICATIONS

- Compaction in confined areas
- Earthwork
- Asphalt and paving applications
- Light to medium patchwork
- Pipeline and trench construction
- Landscaping and gardening

TECHNICAL SPECIFICATIONS  
APF 1033 FORWARD MOVING VIBRATORY PLATE

**DIMENSIONS & WEIGHTS**

MACHINE WEIGHT	54 kg (119 lb)
MACHINE WEIGHT (INCL. OPTIONAL SPRINKLER & WHEELS)	54 kg (119 lb)
A MACHINE LENGTH	635 mm (25 in)
B MACHINE LENGTH (INCL. OPTIONAL SPRINKLER & WHEELS)	635 mm (25 in)
C BASE PLATE LENGTH	497 mm (19.6 in)
D GROUND CONTACT LENGTH	341 mm (13.4 in)
E MACHINE HEIGHT	453 mm (17.8 in)
F WITH HANDLE (WORK)	932 mm (36.7 in)
G WITH HANDLE (TRANSPORT)	1100 mm (43.3 in)
H MACHINE WIDTH	330 mm (13.0 in)

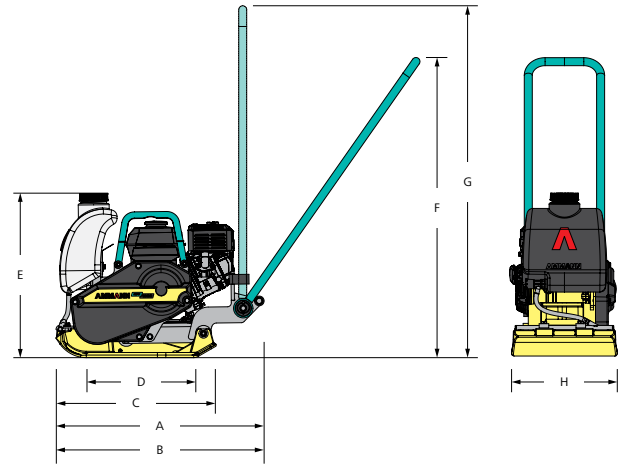

**ENGINE**

ENGINE	Honda GX 120
FUEL	Petrol
ENGINE OUTPUT	2.9 kW (4 HP)
AT RPM	3600

**COMPACTION FORCES**

MAX. VIBRATION FREQUENCY	100 Hz (6000 vpm)
MAX. CENTRIFUGAL FORCE	10.5 kN (2.4 lbf)
WORKING SURFACE	0.11 m <sup>2</sup> (1.18 ft <sup>2</sup> )
MAX. COMPACTION DEPTH (DEPENDING ON GROUND CONDITIONS)	10 cm (3.9 in)

**MISCELLANEOUS**

SPEED	0–22 m/min (0–72.2 ft/min)
GRADEABILITY	30 %
MAX. INCLINE TO ALL SIDES	20 °



**STANDARD**

- Standard vibration isolated guide handle
- Sturdy protection frame with central lifting point
- Powerful and reliable Honda/Subaru petrol engine
- Service friendly exciter unit with expanded life expectancy
- Well protected, sturdy centrifugal clutch and V-Belt

**OPTIONAL EQUIPMENT**

- Corrosion free water tank and sprinkler system for application on bituminous surfaces
- 3 year extended Warranty Program